

ALL DIMENSIONS IN mm

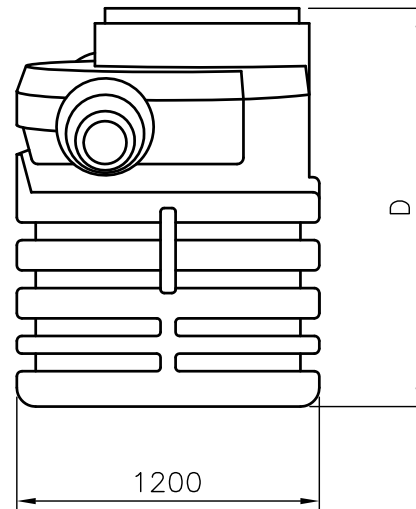
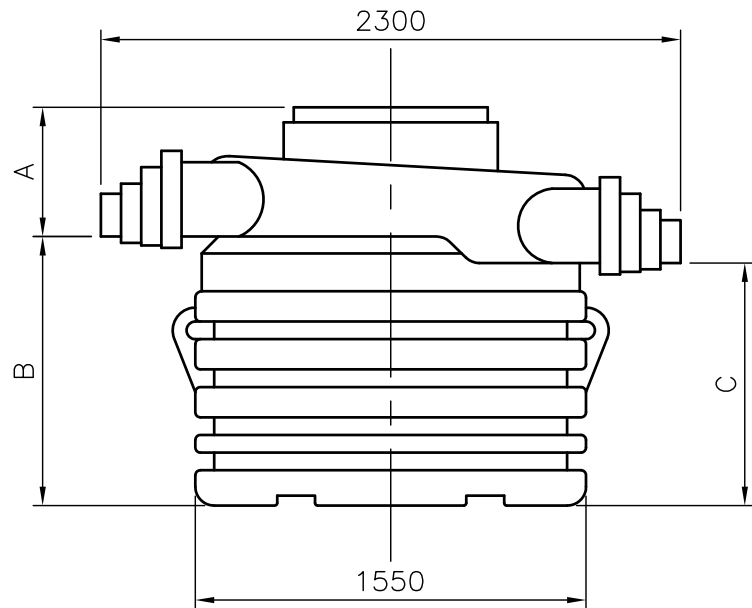
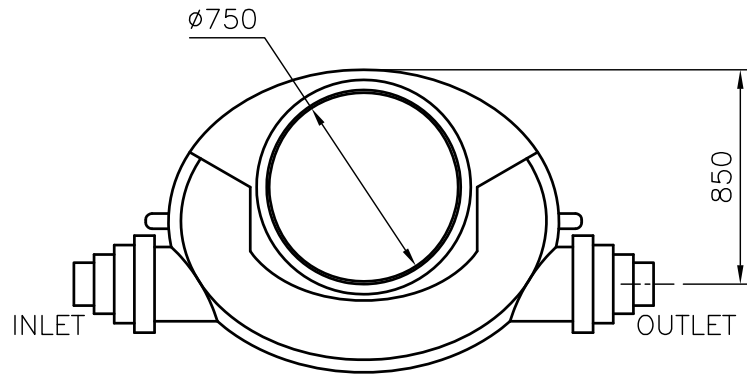

SPECIFICATION:-

CLASS 1 C/W INTEGRAL SILT STORAGE CAPACITY & COALESCING FILTER

MODEL REF	TREATED FLOW L/SEC	PEAK FLOW L/SEC	AREA DRAINED m ²	OIL STORAGE LITRES	SILT STORAGE LITRES	DIMENSION A *	DIMENSION B	DIMENSION C	DIMENSION D
NSB3	3	30	1670	45	300	513	1067	917	1580
NSB6	6	60	3335	90	600	513	1287	1137	1800
NSB8	8	80	4445	120	1000	513	1587	1437	2100
NSB10	10	100	5560	150	1000	513	1587	1437	2100

* RISERS (1000mm) ARE AVAILABLE FOR GREATER INVERT DEPTHS.

OIL & SILT MONITORS/ALARMS ARE AVAILABLE.

INLET/OUTLET CONNECTIONS ARE STEPPED TO SUIT PIPE SIZES:-

160, 225, 300, 375



Croom, Enmore Road, Enmore, Bridgwater, TA5 2AN
Tel: 01278 671297 Fax: 01278 671963
Email: info@synergy-wtp.co.uk Web: www.synergy-wtp.co.uk

Drawing Title:

SYNERGY/ACO RANGE OF
CLASS 1 BYPASS
SEPARATORS

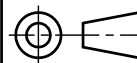

DO NOT
SCALE

REV.	BY	DATE	DESCRIPTION
Drawing No:			Sheet 1 of 1
			PPG3/NSB ACO RANGE
Date:	26 Feb 2013		
Drawn by:	CADraughting		