

IMPORTANT
ALWAYS USE BOTH
LIFTING EYES

LIFTING EYE ASSEMBLY DETAIL
 SCALE 1 : 2

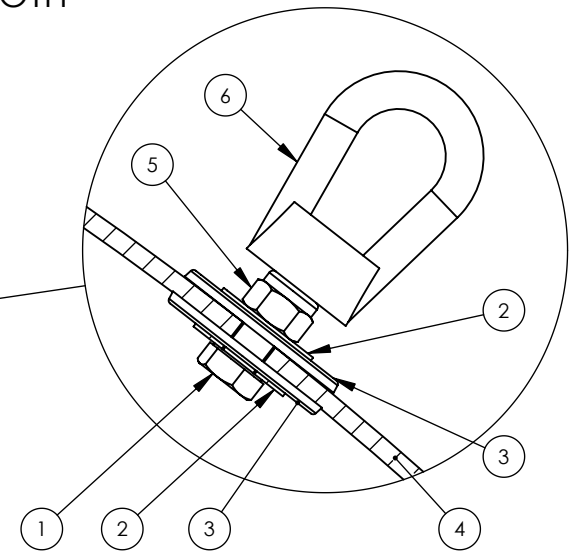
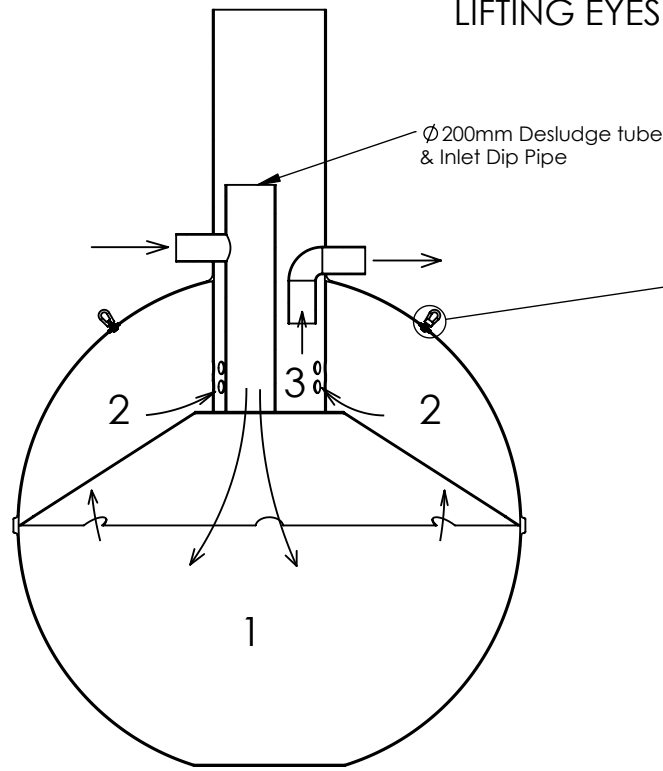

1	M10 STAINLESS STEEL BOLT
2	M10 STAINLESS STEEL PENNY WASHER
3	M10 x 50 NYLON STRUCTURAL WASHER
4	TANK SHELL
5	M10 STAINLESS STEEL NYLOC NUT
6	CE MARKED M10 LIFTING EYE RATED @360kg

SECTION VIEW

ROBUSTA TANK:- THE TOUGH ONE!
BUILT FOR THE JOB
BUILT IN BRITAIN

TANK CAPACITY	DIM A	DIM B	DIM C
2800L	1750	1785	1735
3800L	1940	2000	1950
4600L	2050	2100	2050
6000L	2250	2200	2150

THREE STAGE UPWARD FLOW SEPTIC TANK

Synergy
 WASTEWATER TREATMENT PRODUCTS
 Croom, Enmore Road, Enmore, Bridgwater, Somerset, TA5 2AN
 Tel: 01278 671927 Fax: 01278 671963 E-mail: info@synergy-wtp.co.uk
 Web: www.synergy-wtp.co.uk

Drawing Title:
Synergy Robusta Range
 Spherical Septic tanks
 2,800 - 6,000 litres
 All dimensions in mm SCALE:1:30

REV.	DESCRIPTION

Drawing No: Sheet 1 of 1
SD0901/ROBUSTA
 Date: 05/02/2010
 Drawn by: P Martin