

PLAN VIEW

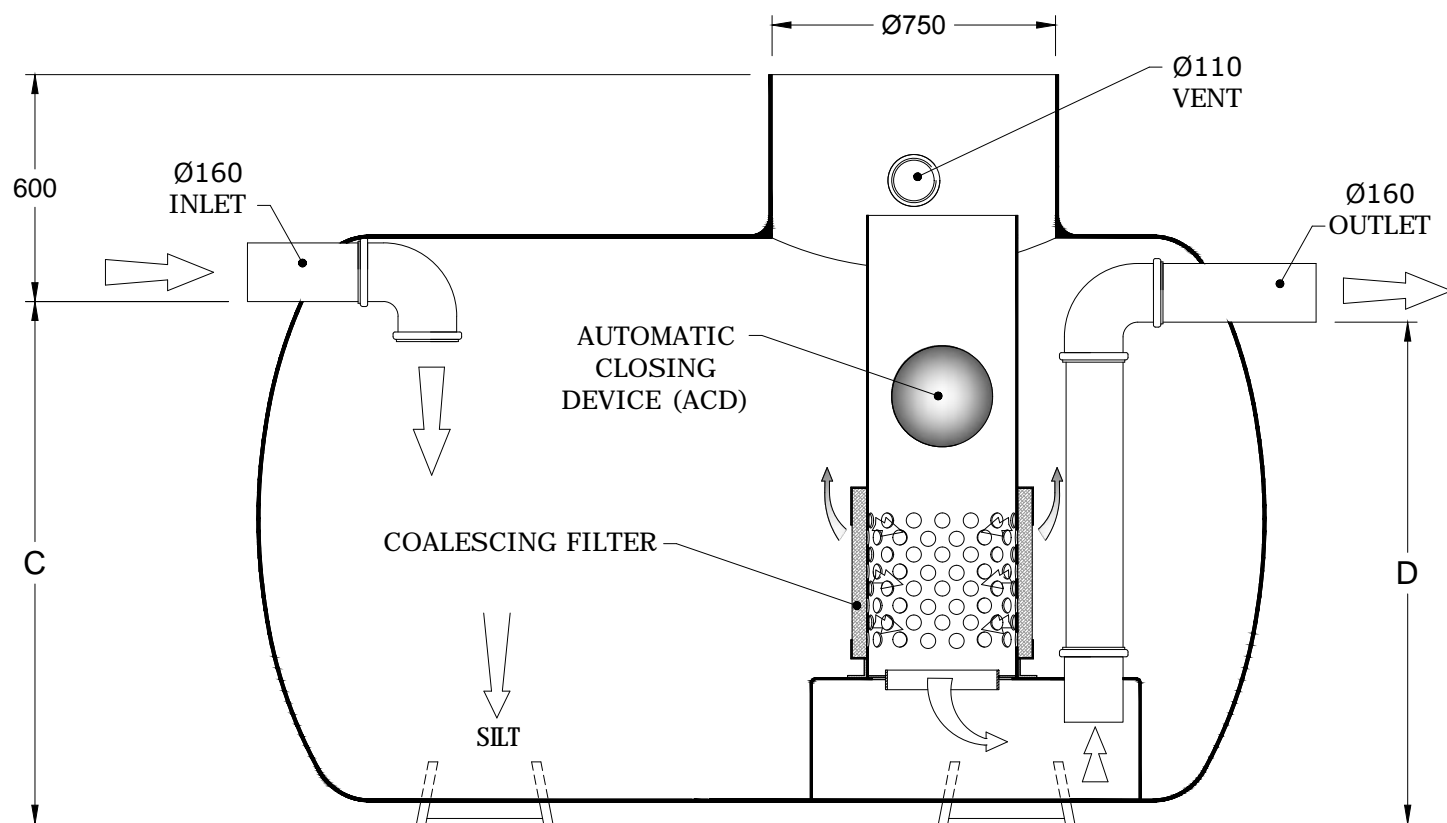

PART SECTION VIEW X-X

FULL RETENTION SEPARATORS

PRODUCT CODE	AREA DRAINED m ²	A mm	B mm	C mm	D mm	OIL STORAGE litres	SILT STORAGE litres
NS3	167	1200	2200	1150	1075	30	300
NS4	222	1500	2200	1400	1325	40	400
NS6	333	1500	2670	1400	1325	60	600
NS8	444	1800	2400	1750	1675	80	800
NS10	556	1800	2700	1750	1675	100	1000
NS15	833	1800	4400	1750	1675	150	1500
NS20	1111	1800	4600	1750	1675	200	2000
NS25	1389	1800	5840	1750	1675	250	2500
NS30	1667	1800	7000	1750	1675	300	3000

FORECOURT SEPARATOR RANGE

PRODUCT CODE	A mm	B mm	C mm
FS/C1/10	1800	4950	1750
FS/C1/12	1800	5800	1750
FS/C1/15	1800	6650	1750



Croom, Enmore Road, Enmore, Bridgwater, Somerset TA5 2AN
 Phone: 0044 (0)1278 671927 Fax: 0044 (0)1278 671963 E-mail: info@synergy-wtp.co.uk
 Web: www.synergy-wtp.co.uk

Drawing Title:

PPG3 COMPLIANT CLASS 1
 FULL RETENTION SEPARATOR.

All dimensions are in mm.

Scale: N.T.S.

Rev:	Revision Details:	Date:	Drawing No :	1011
A	Length Dimensions Update	31.01.18	1st Issue Date :	24/11/2015
			Drawn :	NS
			Chkd :	JN
			Aprvd :	JN

