

ALL DIMENSIONS IN mm

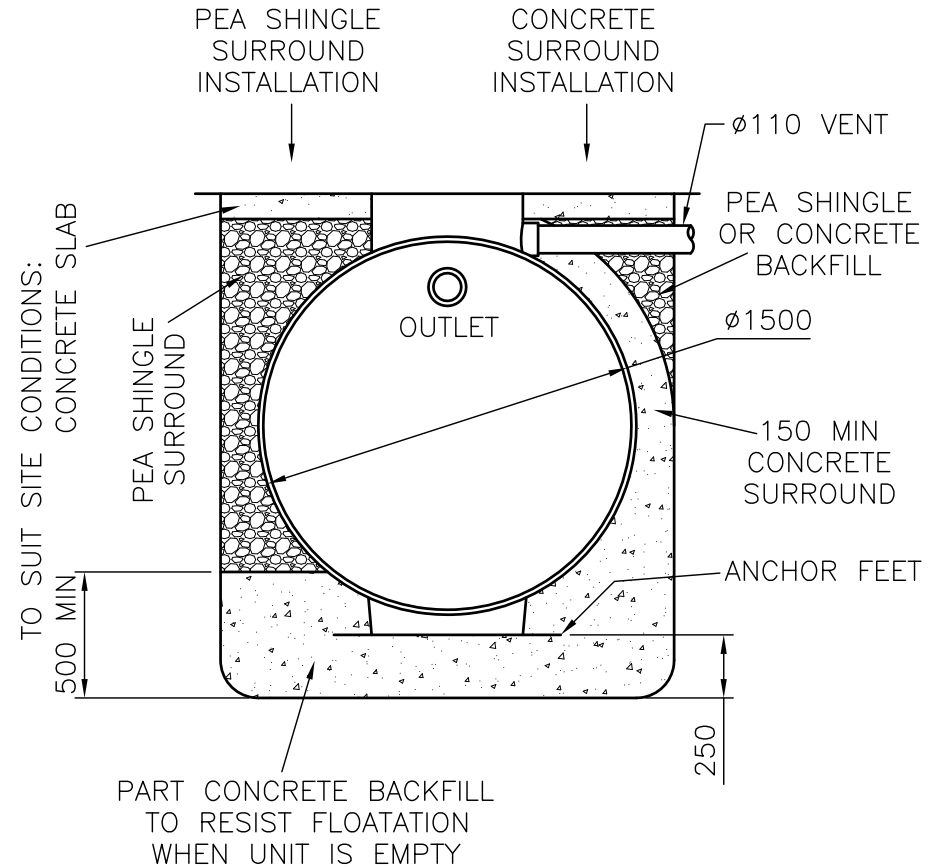
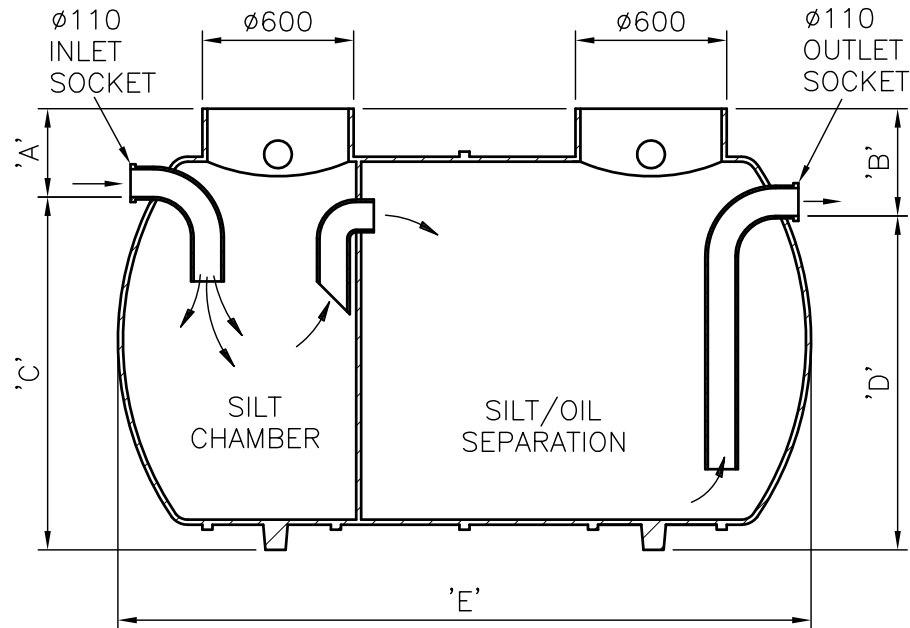

DIMENSIONS:

SIZE	A	B	C	D	E
3600L	350	425	1400	1325	2200
4600L	350	425	1400	1325	2750

NOTES:

1. FLOW RATE ON 3600 LITRE MODEL: 8 LITRES/SECOND
2. FLOW RATE ON 4600 LITRE MODEL: 12 LITRES/SECOND
3. CAN BE SUPPLIED WITH PUMPED OUTLET IF REQUIRED

LARGER CAPACITY MODELS ARE AVAILABLE

Croom, Enmore Road, Enmore, Bridgwater, TA5 2AN  
 Tel: 01278 671297 Fax: 01278 671963  
 Email: info@synergy-wtp.co.uk Web: www.synergy-wtp.co.uk

Drawing Title:  
 AGRICULTURAL  
 SILT/WASHDOWN  
 SEPARATOR

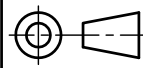

DO NOT  
 SCALE

REV.	BY	DATE	DESCRIPTION
Drawing No: 1003			Sheet: 1 of 1
Date:		8 May 2013	
Drawn by:		CADraughting	