

ALL DIMENSIONS IN mm

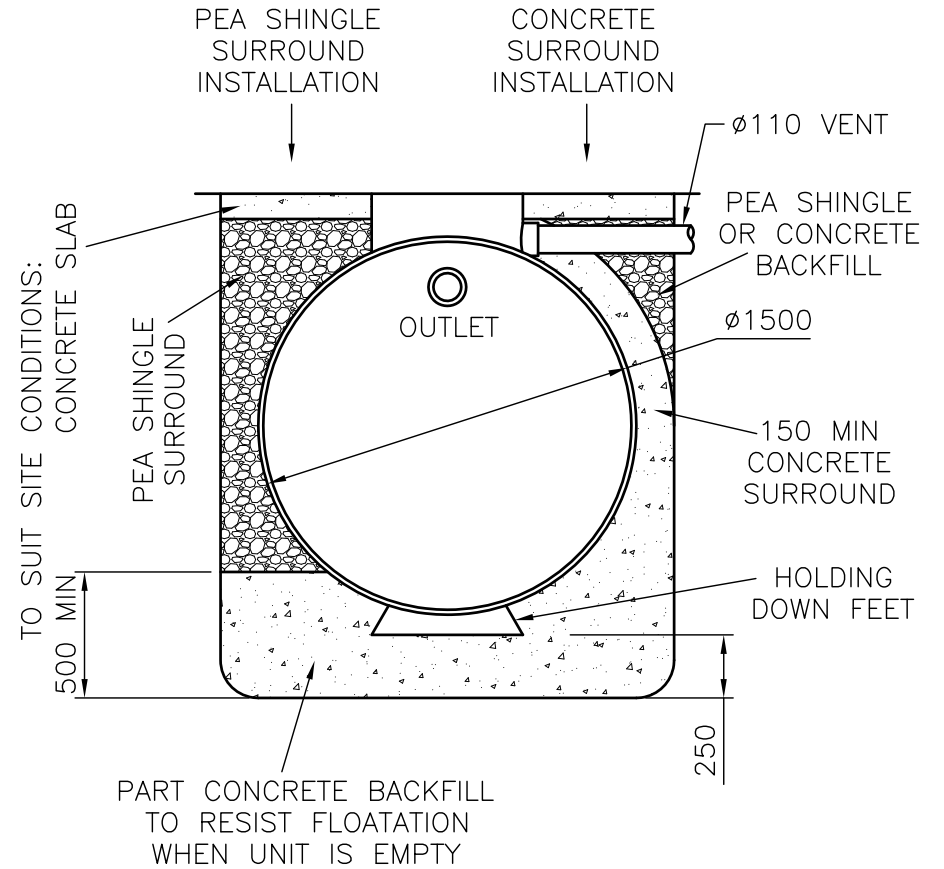
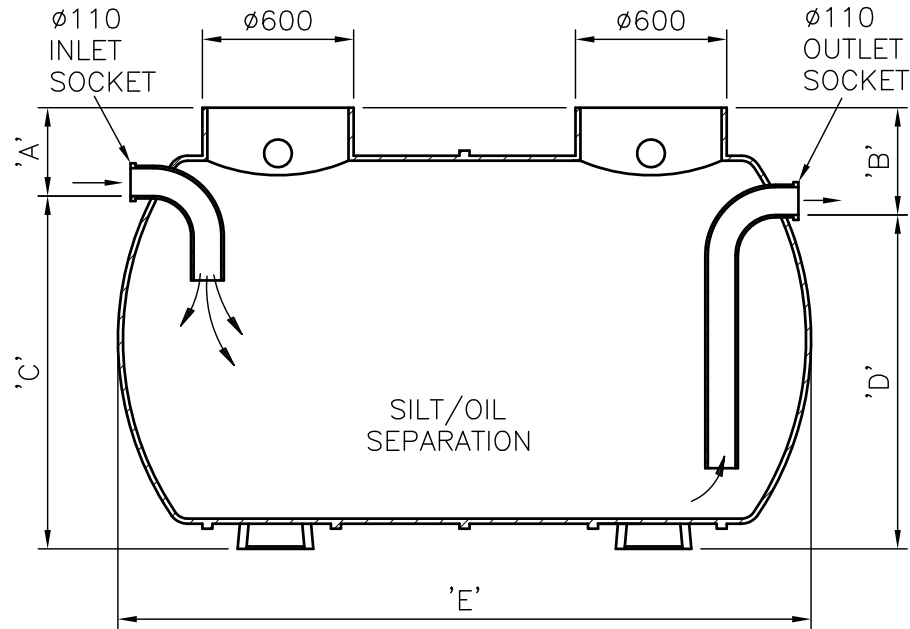

DIMENSIONS:

SIZE	A	B	C	D	E
3600L	350	425	1400	1325	2200
4600L	350	425	1400	1325	2750

NOTES:

1. FLOW RATE ON 3600 LITRE MODEL: 8 LITRES/SECOND
2. FLOW RATE ON 4600 LITRE MODEL: 12 LITRES/SECOND

LARGER CAPACITY MODELS ARE AVAILABLE  
MULTI CHAMBER MODELS ALSO AVAILABLE



Croom, Enmore Road, Enmore, Bridgwater, TA5 2AN  
Tel: 01278 671297 Fax: 01278 671963  
Email: info@synergy-wtp.co.uk Web: www.synergy-wtp.co.uk

Drawing Title:  
SINGLE CHAMBER VEHICLE  
SILT/WASHDOWN  
SEPARATOR

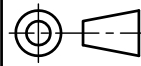

DO NOT  
SCALE

THESE SEPARATORS ARE  
INTENDED TO DISCHARGE  
TO MAIN FOUL SEWERS

REV.	BY	DATE	DESCRIPTION
Drawing No: 1008			Sheet: 1 of 1
Date:		19 May 2013	
Drawn by:		CADraughting	